

- LIT1* distinguish patients with Beckwith-Wiedemann syndrome with cancer and birth defects. *Am J Hum Genet* 70: 604–611
- Engel J, Smallwood A, Harper A, Higgins M, Oshimura M, Reik W, Schofield P, Maher E (2000) Epigenotype-phenotype correlations in Beckwith-Wiedemann syndrome. *J Med Genet* 37:921–926
- Fitzpatrick GV, Soloway PD, Higgins MJ (2002) Regional loss of imprinting and growth deficiency in mice with a targeted deletion of KvDMR1. *Nat Genet* 32:426–431
- Gaston V, Le Bouc Y, Soupre V, Burglen L, Donadieu J, Oro H, Audry G, Vazquez MP, Gicquel C (2001) Analysis of the methylation status of the KCNQ1OT and H19 genes in leukocyte DNA for the diagnosis and prognosis of Beckwith-Wiedemann syndrome. *Eur J Hum Genet* 9:409–418
- Gaston V, Le Bouc Y, Soupre V, Vazquez MP, Gicquel C (2000) Assessment of p57(KIP2) gene mutation in Beckwith-Wiedemann syndrome. *Horm Res* 54:1–5
- Humpherys D, Eggen K, Akutsu H, Hochedlinger K, Rideout WM 3rd, Binizskiewicz D, Yanagimachi R, Jaenisch R (2001) Epigenetic instability in ES cells and cloned mice. *Science* 293:95–97
- Lee M, Debaun M, Mitsuya K, Galonek H, Branderburg S, Oshimura M, Feinberg A (1999) Loss of imprinting of a paternally expressed transcript, with antisense orientation to KvLQT1, occurs frequently in Beckwith-Wiedemann syndrome and is independent of insulin-like growth factor II imprinting. *Proc Natl Acad Sci USA* 96:5203–5208
- Li E (2002) Chromatin modification and epigenetic reprogramming in mammalian development. *Nat Rev Genet* 3:662–673
- Maher ER, Brueton LA, Bowdin SC, Luharia A, Cooper W, Cole TR, Macdonald F, Sampson JR, Barratt CL, Reik W, Hawkins MM (2003) Beckwith-Wiedemann syndrome and assisted reproduction technology (ART). *J Med Genet* 40: 62–64
- Maher ER, Reik W (2000) Beckwith-Wiedemann syndrome: imprinting in clusters revisited. *J Clin Invest* 105:247–252
- Manning M, Lissens W, Bonduelle M, Camus M, De Rijcke M, Liebaers I, Van Steirteghem A (2000) Study of DNA-methylation patterns at chromosome 15q11-q13 in children born after ICSI reveals no imprinting defects. *Mol Hum Reprod* 6:1049–1053
- Mitsuya K, Meguro M, Lee M, Katoh M, Schulz T, Kugoh H, Yoshida M, Niikawa N, Feinberg A, Oshimura M (1999) *LIT1*, an imprinted antisense RNA in the human KvLQT1 locus identified by screening for differentially expressed transcripts using monochromosomal hybrids. *Hum Mol Genet* 8:1209–1217
- Olivennes F, Mannaerts B, Struijs M, Bonduelle M, Devroey P (2001) Perinatal outcome of pregnancy after GnRH antagonist (ganirelix) treatment during ovarian stimulation for conventional IVF or ICSI: a preliminary report. *Hum Reprod* 16: 1588–1591
- Ørstavik KH, Eiklid K, van der Hagen CB, Spetalen S, Kierulf K, Skjeldal O, Buiting K (2003) Another case of imprinting defect in a girl with Angelman syndrome who was conceived by intracytoplasmic sperm injection. *Am J Hum Genet* 72: 218–219
- Reik W, Walter J (2001) Genomic imprinting: parental influence on the genome. *Nat Rev Genet* 2:21–32
- Rideout WM 3rd, Eggen K, Jaenisch R (2001) Nuclear cloning and epigenetic reprogramming of the genome. *Science* 293: 1093–1098
- Smilnich NJ, Day CD, Fitzpatrick GV, Caldwell GM, Lossie AC, Cooper PR, Smallwood AC, Joyce JA, Schofield PN, Reik W, Nicholls RD, Weksberg R, Driscoll DJ, Maher ER, Shows TB, Higgins MJ (1999) A maternally methylated CpG island in KvLQT1 is associated with an antisense paternal transcript and loss of imprinting in Beckwith-Wiedemann syndrome. *Proc Natl Acad Sci USA* 96:8064–8069
- Weksberg R, Nishikawa J, Caluseriu O, Fei YL, Shuman C, Wei C, Steele L, Cameron J, Smith A, Ambus I, Li M, Ray PN, Sadowski P, Squire J (2001) Tumor development in the Beckwith-Wiedemann syndrome is associated with a variety of constitutional molecular 11p15 alterations including imprinting defects of KCNQ1OT1. *Hum Mol Genet* 10:2989–3000
- Young L, Fernandes K, McEvoy T, Butterwith S, Gutierrez C, Carolan C, Broadbent P, Robinson J, Wilmot I, Sinclair K (2001) Epigenetic change in IGF2R is associated with fetal overgrowth after sheep embryo culture. *Nat Genet* 27:153–154
- Young LE, Sinclair KD, Wilmot I (1998) Large offspring syndrome in cattle and sheep. *Rev Reprod* 3:155–163

Address for correspondence and reprints: Dr. Christine Gicquel, Laboratoire d'Explorations Fonctionnelles Endocriniennes, Hôpital Trousseau, 26 Avenue Arnold Netter, 75012 Paris, France. E-mail: christine.gicquel@trs.ap-hop-paris.fr  
© 2003 by The American Society of Human Genetics. All rights reserved.  
0002-9297/2003/7205-0029\$15.00

*Am. J. Hum. Genet.* 72:1341–1346, 2003

### To Trust or Not to Trust an Idiosyncratic Mitochondrial Data Set

*To the Editor:*

In a recent report, Silva et al. (2002) provided partial (8.8 kb) information on the mtDNA coding region (within the region 7148–15946, in the numbering of the Cambridge reference sequence [CRS]; Anderson et al. [1981]) in 40 individuals from Brazil. On the basis of the similarity in nucleotide diversity and age estimates of the four founder haplogroups A, B, C, and D, they claimed to have added new evidence for a single early entry of the founder populations into America. However, a site-by-site audit of the data reveals that their sequences are not of high enough quality to justify such statements. The authors failed to realize that a large number of mutations associated with basal branches of the worldwide mtDNA phylogeny (Finnilä et al. 2001; Maca-Meyer et al. 2001; Torroni et al. 2001; Derbeneva et al. 2002; Herrnstadt et al. 2002; Kivisild et al. 2002) were not correctly scored in their data set.

**Table 1****Sequence Variation in 40 Samples Reported by Silva et al. (2002)**

Sample ID	Haplogroup	Sequence on Region 7148–15976 <sup>a</sup>	Basal Mutations Missed <sup>b</sup>	Accession Number
GRC0149	A	7369 7522G 8027 8794 8860 <u>11335</u> 12007 12705 15326 15524	11719	AF465949
KTN0130	A	8794 8860 11129 11288 11719 12007 12406 12705 14178 14755 14861	15326	AF465956
KPO0013	A	8764 8794 9392 9966 <u>11335</u> 11719 12007 12292G 12314G 12705 13708 <u>14566</u>	8860 15326	AF465957
PTJ0003	A	8794 11719 <u>11944</u> 12007 12705	8860 15326	AF465962
WTE1182	A	8794 8860 11617G 11719 12007 12292G 12618 12705 15326	...	AF465972
WPI0167	A	8794 8860 <u>10398</u> 11719 12007 12705 14978	15326	AF465974
YAN0623	A	8794 8860 10694 11719 12007 12705 13928C 15317 15326	...	AF465975
YAN0665	A	8794 8860 11719 12007 12705 13928C	15326	AF465976
KCR0029	A	8794 8860 9192 <u>10398</u> <u>10400</u> <u>11335</u> 12007 12314G 12705	11719 15326	AF465950
GRC0169	B4b	7626 8860 9950 <u>11335</u> 11719 11821 13590 15326 15535	8281–8289del	AF465953
KTN0209	B4b	8860 11150 11719 13590 14645 14647 15535 15914C	8281–8289del 15326	AF465955
KPO0001	B4b	7369 7522G 8281–8289del 8860 9950 <u>11335</u> 11719 13590 15535	15326	AF465958
KPO0039	B4b	8736 8860 9950 10954 <u>11335</u> 11719 13590 15535	8281–8289del 15326	AF465959
KPO0023	B4b	8552 10604 11719 13590 13708 15535	8281–8289del 8860 15326	AF465960
QUE1876	B4b	8020 8860 <u>11335</u> 11719 12618 13590	8281–8289del 15326 15535	AF465964
QUE1881	B4b	8860 9950 <u>11335</u> 11719 13590 <u>15043</u> 15535	8281–8289del 15326	AF465965
YAN0637	B4b	8860 9950 11177 11719 12155C 13590 13708 15106 15535	8281–8289del 15326	AF465980
KRC0033	B4b	7227T 7251 8860 9950 <u>10398</u> <u>10400</u> <u>11335</u> 11719 13590	8281–8289del 15535 15326	AF465951
QUE1880	B4b	7231C 8860 9950 <u>10398</u> <u>10400</u> <u>11335</u> 11719 12192 13590 15326	8281–8289del 15535	AF465968
JAP1044	B4c/B4a	<u>10115</u> <u>10238del</u> 10398 <u>11335</u> 11719 15326 15346	8281–8289del 8860	AF465948
ARL0058	C	7196A 8078 8584 8701 9540 9545 10398 10400 10873 11719 11914 12705 13263 14783 15043 15301 15326	8860 14318 15487T	AF465945
PTJ0068	C	8701 8860 9540 9545 10873 11719 11914 12705 13263 14318 14783 14788 15043 15914C	7196A 8584 10398 10400 15301 15487T 15326	AF465961
QUE1875	C	7196A 8584 8701 8860 9540 9545 <u>11335</u> 11719 11914 12705 13263 13656 14783 15043 15301	10398 10400 10873 14318 15487T 15326	AF465966
QUE1878	C	8584 8701 9540 9545 10873 <u>11335</u> 11719 11914 12705 13263 13545 14783 15043 15191	7196A 8860 10398 10400 14318 15301 15487T 15326	AF465967
YAN0669	C	8701 8848 8860 9540 9545 10310 10398 10400 11719 11914 12705 13263 13326 14318 14783 15043 15326	7196A 8584 10873 15301 15487T	AF465977
YAN0591	C	8584 8701 8848 8860 9540 9545 10873 11719 11914 12705 13263 13326 14783 15043	7196A 10398 10400 14318 15301 15487T 15326	AF465978

YAN0650	C	<b>7196A</b> 8701 8848 8860 9540 <b>9545</b> 10398 10873 11617G 11719 <b>11914</b> 12705 <b>13263</b> 13326 <b>14318</b> 14783 15043 15301	8584 10400 15487T 15326	AF465979
JAP1045	D4	8701 8860 8964 9296 9540 9824A <u>10115</u> 10398 10873 11719 12705 14783 15043 15301 15326	8414 10400 14668	AF465947
GRC0131	D4	8701 8860 9540 10816T 10873 <u>11335</u> 11914 12705 13059 13067 14783 15043	8414 10398 10400 11719 14668 15301 15326	AF465952
JAP1043	D4	8701 8860 9540 10398 10400 10873 11215 11719 12705 14783 15043 15301 15326 15874	8414 14668	AF465946
KTN0018	D	8701 8860 9540 10873 10874 12705 14687 14783 15043	10398 10400 11719 15301 15326	AF465954
PTJ0001	D	8701 8860 9540 10398 10400 10873 11150 11719 12705 14783 15043 15106 15301	15326	AF465963
TYR0004	D	8701 8860 9540 10398 10400 11719 12406 12705 12810 15301	10873 14783 15043 15326	AF465969
TYR0016	D	8701 8860 10398 10400 10819 10873 10874 11719 12406 12705 12810	9540 14783 15043 15301 15326	AF465970
NGR0524	L2a	<b>7175</b> 7256 <b>7274</b> 7521 <u>8047del</u> 8701 8860 <b>9221</b> 9540 <b>10115</b> 10398 10873 11719 <b>11914</b> <b>11944</b> 12314G <b>12693</b> 12705 <b>13590</b> 13650	7771 8206 13803 14566 15301 15326 15784	AF465941
NGR0522	L2a	7256 <b>7274</b> 7521 7771 8701 8860 <b>9221</b> 9540 10873 10994C 11029T <u>11335</u> 11719 <b>11914</b> <b>11944</b> 12292G <b>12693</b> 12705 <b>13590</b> 13650 <b>13803</b> <b>15784</b> <u>15802del</u> <u>15848del</u>	7175 8206 10115 10398 14566 15301 15326	AF465942
NGR0475	L2a	<b>7175</b> 7256 <b>7274</b> 7521 7771 8701 8860 <b>9221</b> 9540 10373 10873 11719 <b>11914</b> <b>11944</b> <b>12693</b> 12705 <b>13590</b> 13650 <b>13803</b> <u>14668</u> 15784	8206 10115 10398 14566 15301 15326	AF465943
NGR0510	L2a	7256 <b>7274</b> 7521 7771 8701 8860 <b>9221</b> 9540 <b>10115</b> 10398 10873 11617G 11719 <b>11914</b> <b>11944</b> <b>12693</b> 12705 <b>13590</b> 13650 <b>13803</b> 15784	7175 8206 14566 15301 15326	AF465944
WTE1150	L2a	<b>7175</b> 7256 <b>7274</b> 7521 7771 8701 8860 <b>9221</b> <b>10115</b> 10398 10873 <u>11335</u> 11719 <b>11914</b> <b>11944</b> <b>12693</b> 12705 13194 <b>13590</b> 13650 <b>13803</b> 15301 15326 15784	8206 9540 14566	AF465973
WTE1145	U	7220A 7227T 7642 8860 9668 <b>11467</b> 11719 <b>12308</b> <b>12372</b> <u>13590</u> 15326	...	AF465971

NOTE.—Sites are numbered according to the revised reference sequence (Andrews et al. 1999); suffixes A, G, C, and T indicate transversions; “del” indicates a deletion. The mutations in boldface distinguish each sequence from the nearest mtDNA ancestor of haplogroups L2/3, M, N, and R. Potential reading errors or possible phantom mutations are italicized and underlined.

<sup>a</sup> All bear 14766 in addition.

<sup>b</sup> Basal polymorphisms that were undetected or omitted by Silva et al. (2002), including 11719 and the two rare mutations (8860 and 15326) in the CRS.

In the case of the hypervariable segments of the mtDNA control region, Bandelt et al. (2001, 2002) have highlighted lab-specific idiosyncrasies through comparative phylogenetic analysis. For the coding region, the task of identifying anomalies and reconstructing their potential causes is somewhat easier because the vast majority of sites there do not appear to undergo frequent mutations. The coding region well supports a basal nesting of (monophyletic) haplogroups, many of which had already been identified through RFLP analysis and sequencing of the hypervariable segments (Richards and Macaulay 2001). For example, the basal division of Eurasian mtDNAs into macrohaplogroups M and N is amazingly clear cut. The Eurasian mtDNA phylogeny that emerges from the phylogenetic analysis of the complete mtDNA database is detailed (for east Asia) in figure 1 of Kivisild et al. (2002), which attempts a reconstruction of the mutational history. The African mtDNA phylogeny has also been well documented in recent papers (Maca-Meyer et al. 2001; Torroni et al. 2001; Herrnstadt et al. 2002).

Silva et al. (2002) reported 40 mtDNAs, of which they assigned 31 to the Native American haplogroups A, B, C, and D (according to their fig. 1). The remaining nine mtDNAs can be assigned unambiguously to the Asian haplogroups B4 and D4, the Eurasian haplogroup U, and the African haplogroup L2a (table 1), as we will argue below. Figure 1 displays the truncation (relative to the 8.8-kb fragment under study) of the rooted phylogeny that is relevant for assigning these 40 mtDNAs to their respective haplogroups. This phylogeny is unanimously supported by the earlier publications. (However, note that mutations at 15301 and 11944 were not reconstructed most parsimoniously along the African mtDNA tree shown in fig. 1 of Herrnstadt et al. [2002]). The only instances of recurrent mutations (real or not) for the mutations and haplogroups highlighted in figure 1 are then as follows: the transversion 15487T is missing in the single haplogroup C lineage of Maca-Meyer et al. (2001); in the data of Herrnstadt et al. (2002), the B4b lineage 375 has experienced a transition at 14766, the L2a lineage 223 lacks the 7521 transition, and the 14566 transition is missing in the L2a lineage 165, which is closely related to another L2a lineage (bearing the 14566 mutation) from Torroni et al. (2001) in that they both share additional mutations at 3010 and 6663.

It is conspicuous that in all five haplogroup L2a mtDNAs of Silva et al. (2002), two of the basal transitions, 8206 and 14566, characteristic of L2 and L2a, respectively, are missed. Further L2a-diagnostic mutations, such as 7175, 7771, 13803, and 15784, are not always reported in the sequences (table 1). Moreover, the five L2a lineages have a total of only 11 other (private) mutations, comprising as many as five transversions, four deletions, and only two transitions. This pattern of private mutations differs from that in the three

L2a lineages (nine transitions and no other mutations) of Ingman et al. (2000) and Torroni et al. (2001) in the same mtDNA region. It thus looks as though most of the real private mutations in the L2a mtDNAs were missed and that, instead, phantom mutations were scored.

The basal mutation 15487T of haplogroup M8 (which embraces haplogroups C and Z) is omitted in all seven C lineages of Silva et al.'s data (table 1). Other basal mutations for haplogroup C lineages are missing at sites 7196A, 8584, and 14318, in different combinations. It is remarkable that even deep mutations, such as 10400, 10873, and 15301 that distinguish macrohaplogroups M and N, were overlooked in six of the seven C lineages.

Among the seven D lineages in Silva et al. (2002), three sequences share mutations or motifs with D sequences reported elsewhere (Ingman et al. 2000; Derbeneva et al. 2002). The sequence JAP1045 (from an individual of Japanese origin) shares 8964, 9296, and 9824A with a Japanese mtDNA sequence from Ingman et al. (2000) and, therefore, definitely belongs to haplogroup D4, although the two characteristic D4 transitions (8414 and 14668) are not reported in the entire data set, except for one occurrence of 14668 in an L2a sequence! Similarly, the Japanese mtDNA sequence JAP1043 bears one of the mutations, 11215, found in Siberian mtDNAs of haplogroup D4 (Ingman et al. 2000; Derbeneva et al. 2002). The Guarani sequence GRC0131 of Silva et al. (2002) shares a rare transversion 10816T and a rare transition 13059 with the Guarani sequence of Ingman et al. (2000), but only the latter one has 8414 and 14668 and is thus confirmed as belonging to D4. These cases provide strong evidence for the systematic oversight of the basal mutations 8414 and 14668 in all haplogroup D lineages from Silva et al. (2002). Just as in the case of haplogroup C, several of the basal mutations that separate M and N are also missing in most of the D lineages.

Anomalies are also found in the nine sequences belonging to haplogroup A, although it was claimed by Silva et al. (2002) to be "the most homogeneous and best characterized" cluster in figure 1. Sample KCR0029 contains basal mutations 10398 and 10400 for haplogroup M. Sample KPO0013 has the 14566 mutation that is characteristic of haplogroup L2a. Sample PTJ0003 bears the L2abc-specific mutation 11944. Moreover, site 8027 is found mutated in only one A lineage, whereas this mutation was present in all the A sequences in Herrnstadt et al. (2002) and in one Chukchi sequence reported by Ingman et al. (2000).

In the 11 B lineages, only sample KPO0001 has the 9-bp deletion in the COII/tRNA<sup>Lys</sup> intergenic region, characteristic of haplogroup B. One or both of the basal mutations of B4b, 13590 and 15535, occur in all the samples (with the exception of JAP1044) and hint that they belong to B4b. It should be noted that in Herrnstadt

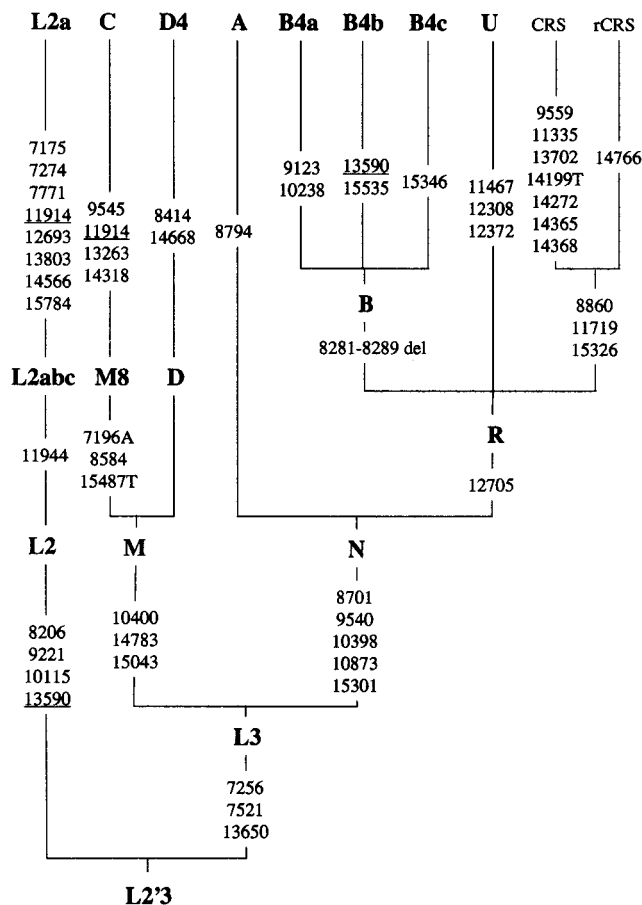

**Figure 1** Skeleton of the basal mtDNA phylogeny for the haplogroups identified in the data of Silva et al. (2002). “CRS” and “rCRS” refer to the reference sequence of Anderson et al. (1981) and the revised reference sequence of Andrews et al. (1999), respectively. The suffixes A, G, C, and T indicate transversions, and “del” indicates a deletion. Parallel mutations in different branches are underlined.

et al. (2002), mutations 9950 and 11177 further defined a subhaplogroup of B4b that was baptized “B2.” We suggest that the 11177 mutation could have been omitted by Silva et al. (2002) as well. The Japanese B lineage JAP1044 could belong to haplogroup B4c or, alternatively, to B4a, as judged by the 15346 mutation or the 10238 transition, respectively (if the latter was simply misreported as a deletion). Two samples, KRC0033 and QUE1880, bear the 10400 mutation of haplogroup M, whereas sample QUE1881 harbors the 15043 mutation of M.

The U sequence in Silva et al. (2002) contains the full motif of haplogroup U, plus two transversions and three transitions not previously found in the published U sequences (Ingman et al. 2000; Finnilä et al. 2001; Maca-Meyer et al. 2001; Herrnstadt et al. 2002).

Rare deletions are found in two L2a and one B lineage of Silva et al. (2002). The 15802delA and 15848delA

in the cytochrome *b* gene of sample NGR0522, 8047delT in the COII gene of sample NGR0524, and 10238delT in the ND3 gene of sample JAP1044 generate premature stop codons in these genes. These rare deletions all occur at a 2-bp repeat of the deleted base and might be generated by the Sequencer reading program. It is clear that the sequences of Silva et al. (2002) harbor more rare transversions and fewer private transitions than other reported sequences (Ingman et al. 2000; Finnilä et al. 2001; Maca-Meyer et al. 2001; Torroni et al. 2001; Herrnstadt et al. 2002). One cannot exclude the possibility that true transitions were erroneously scored as transversions or deletions by Silva et al. (2002). The two rare mutations 8860 and 15326 of the CRS are also missed in most of the sequences. The mutation 11335 in the CRS, which was found to be a sequencing error (Andrews et al. 1999), was present in 16 mtDNAs.

Processes that could account for these anomalies include the following:

1. Only one strand of mtDNA was sequenced;
2. Sequences were aligned with some variant of the CRS (a likely source of problems in the past; see Macaulay et al. [1999]);
3. Sequences from different samples, especially those belonging to different haplogroups, were aligned together during the editing process (In this way, one might easily “borrow” a fragment of one sample into another when the sequences of the latter were not overlapping and, thus, introduce basal polymorphisms of one mtDNA lineage into another);
4. Possible sample crossover or contamination during data collection;
5. Relying just on the sequence scored by the Sequencer reading program without further manual checking of the chromatogram, especially relevant in the case of the rare deletions; and/or
6. PCR errors during amplification.

In summary, we have every reason to mistrust the mtDNA sequences published by Silva et al. (2002). One cannot escape the conclusion that these data are seriously flawed or, at least, are not mtDNA as we know it.

YONG-GANG YAO,<sup>1</sup> VINCENT MACAULAY,<sup>3</sup>  
TOOMAS KIVISILD,<sup>4</sup> YA-PING ZHANG,<sup>1,2</sup>  
AND HANS-JÜRGEN BANDELT<sup>5</sup>

<sup>1</sup>Kunming Institute of Zoology, Chinese Academy of Sciences, and <sup>2</sup>Laboratory for Conservation and Utilization of Bio-Resource, Yunnan University, Kunming, Yunnan, China; <sup>3</sup>Department of Statistics, University of Oxford, Oxford, United Kingdom; <sup>4</sup>Institute of Molecular and Cell Biology, Tartu University, Tartu, Estonia; and <sup>5</sup>Fachbereich Mathematik, Universität Hamburg, Hamburg

## References

- Anderson S, Bankier AT, Barrell BG, de Bruijn MH, Coulson AR, Drouin J, Eperon IC, Nierlich DP, Roe BA, Sanger F, Schreier PH, Smith AJ, Staden R, Young IG (1981) Sequence and organization of the human mitochondrial genome. *Nature* 290:457–465
- Andrews RM, Kubacka I, Chinnery PF, Lightowlers RN, Turnbull DM, Howell N (1999) Reanalysis and revision of the Cambridge reference sequence for human mitochondrial DNA. *Nat Genet* 23:147
- Bandelt H-J, Lahermo P, Richards M, Macaulay V (2001) Detecting errors in mtDNA data by phylogenetic analysis. *Int J Legal Med* 115:64–69
- Bandelt H-J, Quintana-Murci L, Salas A, Macaulay V (2002) The fingerprint of phantom mutations in mitochondrial DNA data. *Am J Hum Genet* 71:1150–1160
- Derbeneva OA, Sukernik RI, Volodko NV, Hosseini SH, Lott MT, Wallace DC (2002) Analysis of mitochondrial DNA diversity in the Aleuts of the Commander Islands and its implications for the genetic history of Beringia. *Am J Hum Genet* 71:415–421
- Finnilä S, Lehtonen MS, Majamaa K (2001) Phylogenetic network for European mtDNA. *Am J Hum Genet* 68:1475–1484
- Herrnstadt C, Elson JL, Fahy E, Preston G, Turnbull DM, Anderson C, Ghosh SS, Olefsky JM, Beal MF, Davis RE, Howell N (2002) Reduced-median-network analysis of complete mitochondrial DNA coding-region sequences for the major African, Asian, and European haplogroups. *Am J Hum Genet* 70:1152–1171; 71:448–449 (erratum)
- Ingman M, Kaessmann H, Pääbo S, Gyllensten U (2000) Mitochondrial genome variation and the origin of modern humans. *Nature* 408:708–713
- Kivisild T, Tolk H-V, Parik J, Wang Y, Papiha SS, Bandelt H-J, Villems R (2002) The emerging limbs and twigs of the East Asian mtDNA tree. *Mol Biol Evol* 19:1737–1751
- Maca-Meyer N, González AM, Larruga JM, Flores C, Cabrera VC (2001) Major genomic mitochondrial lineages delineate early human expansions. *BMC Genetics* 2:13
- Macaulay V, Richards M, Sykes B (1999) Mitochondrial DNA recombination: no need to panic. *Proc R Soc Lond B* 266: 2037–2039
- Richards M, Macaulay V (2001) The mitochondrial gene tree comes of age. *Am J Hum Genet* 68:1315–1320
- Silva WA Jr, Bonatto SL, Holanda AJ, Ribeiro-dos-Santos AK, Paixão BM, Goldman GH, Abe-Sandes K, Rodriguez-Delfin L, Barbosa M, Paçó-Larson ML, Petzl-Erler ML, Valente V, Santos SEB, Zago MA (2002) Mitochondrial genome diversity of Native Americans supports a single early entry of founder populations into America. *Am J Hum Genet* 71:187–192
- Torrioni A, Rengo C, Guida V, Cruciani F, Sellitto D, Coppa A, Luna Calderon F, Simionati B, Valle G, Richards M, Macaulay V, Scozzari R (2001) Do the four clades of the mtDNA haplogroup L2 evolve at different rates? *Am J Hum Genet* 69:1348–1356

Address for correspondence and reprints: Dr. Yong-Gang Yao, Kunming Institute of Zoology, Chinese Academy of Sciences, 32 Jiaochang Donglu, Kunming, Yunnan, 650223, China. E-mail: ygyaozh@yahoo.com

© 2003 by The American Society of Human Genetics. All rights reserved. 0002-9297/2003/7205-0030\$15.00

*Am. J. Hum. Genet.* 72:1346–1348, 2003

## Correction: Mitochondrial DNA Variation in Amerindians

*To the Editor:*

We thank Yao et al. (2003 [in this issue]) for calling our attention to inconsistencies in our data reporting mitochondrial DNA variations in Amerindians (Silva et al. 2002). We reviewed the original chromatograms and re-sequenced all the samples (forward and reverse). On the basis of the reanalysis of the initial data and sequencing that has been repeated, we conclude that most criticisms of Yao et al. are correct. We identified two sources of problems: (a) alignment with a variant CRS (Macaulay et al. 1999) and (b) mutations missed at regions of low-quality chromatograms in one (forward or reverse) of the first sequencing. Elimination of these two problems, by a second (and, in a few cases, a third) sequencing, careful manual checking of the chromatograms, and use of the correct rCRS reference sequence (MITOMAP) eliminated the discrepancies. A summary of all 40 corrected sequences is presented in figure 1, and the general pattern is similar to that recently reported by Herrnstadt et al. (2002). The presence of a private mutation in more than one individual or the absence of a basal mutation probably represent examples of homoplasmy or of reverse mutations. Extensive homoplasmy within the coding region of mtDNA has been documented (Eyre-Walker et al. 1999; Herrnstadt et al. 2002) and will probably be found more often as the number of mtDNA samples sequenced increases. For instance, the group C basal mutation 9545G was found in one individual from the haplogroup A, whereas private mutation 14460G was found in two individuals who belong to haplogroups A and D, and 15670C is present in one individual who belongs to haplogroup A and two who belong to haplogroup C (Herrnstadt et al. 2002). The finding of two similar private mutations (12406A) in two individuals of the same tribe (TYR0004 and TYR0016) is probably the consequence of a single mutational event, as is the occurrence of the reverse mutation 8584 in two individuals of another tribe (YAN0669 and YAN0650).

Recalculation of the age estimates for the four founder haplogroups on the basis of the reviewed data continues

	777777777	777888888	888888888	999999999	111111111	111111111	111111111	111111111	111111111	111111111	111111111	111111111	111111111	111111111	111111111	111111111	111111111
	1122222456	6670022445	5677778891	2235556899	9113334666	8888899112	2344678889	9012334466	6780122355	6667789113	356777789	0113333334	556777889				
	7922557022	4972705135	8403694669	2994496225	6151790009	1177957571	8656112881	4099070117	9015926249	5590102791	766568867	4090112448	134238271				
	5607164216	2717861452	4816448042	1620518480	6590380494	6934046075	8527791144	4722826882	3509413650	0628638878	068563818	3611376567	456714644				
Mitomap rCR5	TCTGTCCCGC	GGAGGGGCAT	GGATGCTACG	ACATAGCTAT	GTCGGACTTA	AATCACCGCC	CTTATGACAG	TGGTAGGAGA	ACACGAATCG	CTCGAAGTTT	AACACTTGA	GGTGTGATGA	TCCCGTAAA				
GRC0149 A	.....A.....	.....T.G.....	.....G.....	.....C.....	.....A.....	.....AG.....	.....A.....	.....A.....	.....T.....	.....G.....	.....T.....	.....G.....	.....T.....				
KTN0130 A	.....A.....	.....T.G.....	.....G.....	.....C.....	.....A.....	.....AG.....	.....A.....	.....A.....	.....T.....	.....G.....	.....T.....	.....G.....	.....T.....				
KPO0013 A	.....A.....	.....A.AT.G.....	.....G.....	.....A.....	.....A.....	.....AG.....	.....A.....	.....A.....	.....T.....	.....G.....	.....T.....	.....G.....	.....T.....				
PTJ0003 A	.....A.....	.....T.G.....	.....G.....	.....C.....	.....A.....	.....AG.....	.....A.....	.....A.....	.....T.....	.....G.....	.....T.....	.....G.....	.....T.....				
WTE1182 A	.....T.....	.....A.....	.....T.G.....	.....G.....	.....A.....	.....AG.....	.....A.....	.....A.....	.....T.....	.....G.....	.....T.....	.....G.....	.....T.....				
WPI0167 A	.....A.....	.....G.T.G.....	.....G.....	.....C.....	.....A.....	.....AG.....	.....A.....	.....A.....	.....T.....	.....G.....	.....T.....	.....G.....	.....T.....				
YAN0623 A	.....A.....	.....T.G.....	.....G.....	.....C.....	.....A.....	.....AG.....	.....A.....	.....A.....	.....T.....	.....G.....	.....T.....	.....G.....	.....T.....				
YAN0665 A	.....A.....	.....T.G.....	.....G.....	.....C.....	.....A.....	.....AG.....	.....A.....	.....A.....	.....T.....	.....G.....	.....T.....	.....G.....	.....T.....				
KCR0029 A	.....A.....	.....T.G.A.....	.....G.....	.....C.....	.....A.....	.....AG.....	.....A.....	.....A.....	.....T.....	.....G.....	.....T.....	.....G.....	.....T.....				
GRC0169 B4b	.....T.....	.....G.....	.....G.....	.....C.....	.....A.....	.....AG.....	.....A.....	.....A.....	.....T.....	.....G.....	.....T.....	.....G.....	.....T.....				
KTN0209 B4b	.....G.....	.....G.....	.....G.....	.....C.....	.....A.....	.....AG.....	.....A.....	.....A.....	.....T.....	.....G.....	.....T.....	.....G.....	.....T.....				
KPO0001 B4b	.....G.....	.....G.....	.....G.....	.....C.....	.....A.....	.....AG.....	.....A.....	.....A.....	.....T.....	.....G.....	.....T.....	.....G.....	.....T.....				
KPO0039 B4b	.....C.....	.....G.....	.....G.....	.....C.....	.....A.....	.....AG.....	.....A.....	.....A.....	.....T.....	.....G.....	.....T.....	.....G.....	.....T.....				
KPO0023 B4b	.....C.....	.....G.....	.....G.....	.....C.....	.....A.....	.....AG.....	.....A.....	.....A.....	.....T.....	.....G.....	.....T.....	.....G.....	.....T.....				
QUE1876 B4b	.....T.....	.....G.....	.....G.....	.....C.....	.....A.....	.....AG.....	.....A.....	.....A.....	.....T.....	.....G.....	.....T.....	.....G.....	.....T.....				
QUE1881 B4b	.....G.....	.....G.....	.....G.....	.....C.....	.....A.....	.....AG.....	.....A.....	.....A.....	.....T.....	.....G.....	.....T.....	.....G.....	.....T.....				
YAN0637 B4b	.....A.....	.....G.....	.....G.....	.....C.....	.....A.....	.....AG.....	.....A.....	.....A.....	.....T.....	.....G.....	.....T.....	.....G.....	.....T.....				
KRC0033 B4b	.....TC.....	.....G.....	.....G.....	.....C.....	.....A.....	.....AG.....	.....A.....	.....A.....	.....T.....	.....G.....	.....T.....	.....G.....	.....T.....				
QUE1880 B4b	.....G.....	.....G.....	.....G.....	.....C.....	.....A.....	.....AG.....	.....A.....	.....A.....	.....T.....	.....G.....	.....T.....	.....G.....	.....T.....				
JAP1044 B4c	.....G.....	.....G.....	.....G.....	.....C.....	.....A.....	.....AG.....	.....A.....	.....A.....	.....T.....	.....G.....	.....T.....	.....G.....	.....T.....				
ARL0058 C	.....A.....	.....A.....	.....A.G.....	.....G.....	.....CG.....	.....GT.....	.....C.....	.....A.....	.....A.....	.....T.....	.....G.....	.....C.....	.....TC.....	.....A.....	.....A.....	.....G.....	.....T.....
PTJ0068 C	.....A.....	.....A.....	.....A.G.....	.....G.....	.....CG.....	.....GT.....	.....C.....	.....A.....	.....A.....	.....T.....	.....G.....	.....C.....	.....TCC.....	.....A.....	.....AA.....	.....G.....	.....T.....
QTE1875 C	.....A.....	.....A.....	.....A.G.....	.....G.....	.....CG.....	.....GT.....	.....C.....	.....A.....	.....A.....	.....T.....	.....G.....	.....C.....	.....C.....	.....TC.....	.....A.....	.....A.....	.....G.....
QTE1878 C	.....A.....	.....A.....	.....A.G.....	.....G.....	.....CG.....	.....GT.....	.....C.....	.....A.....	.....A.....	.....T.....	.....G.....	.....C.....	.....TC.....	.....A.....	.....CA.....	.....G.....	.....T.....
YAN0669 C	.....A.....	.....A.....	.....A.G.....	.....CG.....	.....CG.....	.....C.....	.....A.....	.....GT.....	.....C.....	.....A.....	.....A.....	.....T.....	.....GC.....	.....C.....	.....TC.....	.....A.....	.....A.....
YAN0591 C	.....A.....	.....A.....	.....A.G.....	.....CG.....	.....CG.....	.....GT.....	.....C.....	.....A.....	.....A.....	.....T.....	.....GC.....	.....C.....	.....TC.....	.....A.....	.....A.....	.....G.....	.....T.....
YAN0650 C	.....A.....	.....A.....	.....G.....	.....CG.....	.....CG.....	.....G.....	.....C.....	.....A.....	.....A.....	.....T.....	.....GC.....	.....C.....	.....TC.....	.....A.....	.....A.....	.....G.....	.....T.....
JAP1045 D4	.....T.....	.....G.....	.....G.....	.....GT.....	.....T.C.....	.....A.....	.....C.....	.....G.....	.....C.....	.....A.....	.....A.....	.....T.....	.....TC.....	.....A.....	.....A.....	.....G.....	.....T.....
GRC0131 D4	.....T.....	.....G.....	.....G.....	.....G.....	.....C.....	.....GT.....	.....C.....	.....T.....	.....C.....	.....A.....	.....A.....	.....T.....	.....TC.....	.....A.....	.....A.....	.....G.....	.....C.....
JAP1043 D4	.....T.....	.....G.....	.....G.....	.....G.....	.....C.....	.....GT.....	.....C.....	.....T.....	.....C.....	.....A.....	.....A.....	.....T.....	.....TC.....	.....A.....	.....A.....	.....G.....	.....T.....
KTN0018 D	.....T.....	.....G.....	.....G.....	.....G.....	.....C.....	.....GT.....	.....C.....	.....T.....	.....C.....	.....A.....	.....A.....	.....T.....	.....TC.....	.....A.....	.....A.....	.....G.....	.....T.....
PTJ0001 D	.....T.....	.....G.....	.....G.....	.....G.....	.....C.....	.....GT.....	.....C.....	.....T.....	.....C.....	.....A.....	.....A.....	.....T.....	.....TC.....	.....A.....	.....A.....	.....G.....	.....T.....
TYR0004 D	.....T.....	.....G.....	.....G.....	.....G.....	.....C.....	.....GT.....	.....C.....	.....T.....	.....C.....	.....A.....	.....A.....	.....T.....	.....TC.....	.....A.....	.....A.....	.....G.....	.....T.....
TYR0016 D	.....T.....	.....G.....	.....G.....	.....G.....	.....C.....	.....GT.....	.....C.....	.....T.....	.....C.....	.....A.....	.....A.....	.....T.....	.....TC.....	.....A.....	.....A.....	.....G.....	.....T.....
NGR0524 L2a	.....C.....	.....TT.A.....	.....G.....	.....A.....	.....G.....	.....G.....	.....G.....	.....C.....	.....C.....	.....G.....	.....C.....	.....A.....	.....A.....	.....C.....	.....GT.....	.....A.....	.....T.....
NGR0522 L2a	.....C.....	.....TT.A.....	.....G.....	.....A.....	.....G.....	.....G.....	.....G.....	.....C.....	.....C.....	.....GT.....	.....C.....	.....A.....	.....A.....	.....C.....	.....GT.....	.....A.....	.....T.....
NGR0475 L2a	.....C.....	.....TT.A.....	.....G.....	.....A.....	.....G.....	.....G.....	.....G.....	.....C.....	.....C.....	.....AG.....	.....C.....	.....A.....	.....A.....	.....C.....	.....GT.....	.....A.....	.....T.....
NGR0510 L2a	.....C.....	.....TT.A.....	.....G.....	.....A.....	.....G.....	.....G.....	.....G.....	.....C.....	.....C.....	.....G.....	.....C.....	.....A.....	.....A.....	.....C.....	.....GT.....	.....A.....	.....T.....
WTE1150 L2a	.....C.....	.....TT.A.....	.....G.....	.....A.....	.....G.....	.....G.....	.....G.....	.....C.....	.....C.....	.....G.....	.....C.....	.....A.....	.....A.....	.....C.....	.....GT.....	.....A.....	.....T.....
WTE1145 U	.....A.....	.....A.....	.....G.....	.....A.....	.....G.....	.....G.....	.....G.....	.....C.....	.....C.....	.....G.....	.....C.....	.....A.....	.....A.....	.....C.....	.....GT.....	.....A.....	.....T.....

**Figure 1** Data matrix showing the corrected informative nucleotide positions for the 8.8-kb mtDNA segment for 40 individuals sequenced by us

**Table 1****Nucleotide Diversity and Age Estimates for mtDNA Belonging to the Four Founder Haplogroups of New World Natives**

Haplogroup	No. of Sequences	Genetic Diversity <sup>a</sup> (SE)	Mean Age in Years <sup>b</sup> (95% CI)
A	10	0.73 (0.15)	15,398 (12,052–18,744)
B	11	0.75 (0.14)	15,819 (12,659–18,970)
C	9	0.64 (0.13)	13,520 (10,616–17,425)
D	5	0.86 (0.18)	18,144 (14,137–22,151)
Weighted mean		0.75 (0.15)	15,720 (12,366–19,074)

<sup>a</sup>  $\pi (\times 10^{-3})$ .<sup>b</sup> Calculated as in Silva et al. (2002).

to show similarities between the four haplogroups and does not differ significantly from the previously published values (table 1). This supports our primary conclusion in favor of a single migration wave, with a mean age for the four haplogroups of 12,366–19,074 years before present.

The revised versions of the sequences have been submitted to GenBank.

WILSON A. SILVA JR.,<sup>1</sup> SANDRO L. BONATTO,<sup>4</sup>  
ADRIANO J. HOLANDA,<sup>1</sup>  
ANDREA K. RIBEIRO-DOS-SANTOS,<sup>5</sup>  
BEATRIZ M. PAIXÃO,<sup>1</sup> GUSTAVO H. GOLDMAN,<sup>2</sup>  
KIYOKO ABE-SANDES,<sup>1,8</sup> LUIS RODRIGUEZ-DELFIN,<sup>6</sup>  
MARCELA BARBOSA,<sup>2</sup> MARIA LUIZA PAÇÓ-LARSON,<sup>3</sup>  
MARIA LUIZA PETZL-ERLER,<sup>7</sup> VALERIA VALENTE,<sup>3</sup>  
SIDNEY E. B. SANTOS,<sup>5</sup> AND MARCO A. ZAGO<sup>1</sup>

<sup>1</sup>Center for Cell Therapy and Regional Blood Center,

<sup>2</sup>Faculdade de Ciências Farmacêuticas de Ribeirão

Preto, and <sup>3</sup>Department of Cell and Molecular

Biology and Pathogenic Agents, Faculty of Medicine

of Ribeirão Preto, Ribeirão Preto, Brazil; <sup>4</sup>Centro de

Biologia Genômica e Molecular, Pontifícia

Universidade Católica do Rio Grande do Sul, Porto

Alegre, Brazil; <sup>5</sup>Laboratory of Human and Medical

Genetics, University of Para, Belem, Brazil; <sup>6</sup>Unidad

de Biología Molecular, Facultad de Medicina,

Universidad Nacional de Trujillo, Trujillo, Peru;

<sup>7</sup>Laboratory of Human Molecular Genetics,

Department of Genetics, Federal University of Parana,

Curitiba, Brazil; <sup>8</sup>Universidade Estadual do Sudoeste

da Bahia, Jequié, Brazil

### Electronic-Database Information

The URL for data presented herein is as follows:

MITOMAP, <http://www.mitomap.org> (for a human mitochondrial genome database)

### References

- Eyre-Walker A, Smith NH, Maynard Smith J (1999) Reply to Macaulay et al (1999): mitochondrial DNA recombination: reasons to panic. *Proc R Soc Lond B* 266:2041–2042
- Herrnstadt C, Elson JL, Fahy E, Preston G, Turnbull DM, Anderson C, Ghosh SS, Olefsky JM, Beal MF, Davis RE, Howell N (2002) Reduced-median-network analysis of complete mitochondrial DNA coding-region sequences for the major African, Asian, and European haplogroups. *Am J Hum Genet* 70:1152–1171
- Macaulay V, Richards M, Sykes B (1999) Mitochondrial DNA recombination: no need to panic. *Proc R Soc Lond B* 266:2037–2039
- Silva WA Jr, Bonatto SL, Holanda AJ, Ribeiro-dos-Santos AK, Paixão BM, Goldman GH, Abe-Sandes K, Rodriguez-Delfin L, Barbosa M, Paçó-Larson ML, Petzl-Erler ML, Valente V, Santos SEB, Zago MA (2002) Mitochondrial genome diversity of Native Americans supports a single early entry of founder populations into America. *Am J Hum Genet* 71:187–192
- Yao Y-G, Macaulay V, Kivisild T, Zhang Y-P, Bandelt H-J (2003) To trust or not to trust an idiosyncratic mitochondrial data set. *Am J Hum Genet* 72:1341–1346 (in this issue)

Address for correspondence and reprints: Dr. Marco A. Zago, Center for Cell Therapy and Regional Blood Center, 14051-140 Ribeirão Preto, Brazil. E-mail: marazago@usp.br

© 2003 by The American Society of Human Genetics. All rights reserved. 0002-9297/2003/7205-0031\$15.00

*Am. J. Hum. Genet.* 72:1348–1349, 2003

### Reply to Silva et al.

*To the Editor:*

Silva et al. (2003 [in this issue]) have certainly improved their data by eliminating many of the errors in the current version of the data matrix, and they have admitted most of their innocent mistakes. Their efforts and atti-



tude should be encouraged (cf. Forster 2003). However, we are still skeptical about the corrected results presented in figure 1, for some idiosyncrasies remain and others seem to have been newly introduced. For example, some sites (e.g., 8584, 14318 [YAN0591; C type] and 14783 [TYR0004; D type]), at which Silva et al. (2003 [in this issue]) have now corrected some of the entries in their original data table, still show back mutations. Homoplasmy in the coding region is much less than in the control region and may have only a few hot spots (see, e.g., table 2 of Herrnstadt et al. [2002]); the reference to Eyre-Walker et al. (1999) is not really relevant, since those authors have taken quite problematic data at face value (Kivisild and Villems 2000). The recorded variation at 10400 remains highly suspicious. It is hard to believe that 10400 has actually mutated in two B types (KRC0033 and QUE1880) and one L2a type (NGR0522) and reverted in two C types (QTE1875 and YAN0650) and two D4 types (JAP1045 and GRC0131), because no single homoplasious change at this site has been observed in >900 coding-region sequences or fragments that cover site 10400 from Ingman et al. (2000), Maca-Meyer et al. (2001), Derbeneva et al. (2002), Herrnstadt et al. (2002), and Yao et al. (2002). Moreover, site 11177 is found in only 2 of 10 B4b mtDNAs of Silva et al., which contrasts to the co-occurrence of 11177 and 9950 in all 14 B4b mtDNAs of Herrnstadt et al. (2002). To thoroughly settle these anomalies, it is imperative that the authors take notice of the potential processes that might introduce errors, as listed in our letter (Yao et al. 2003 [in this issue]), especially sample crossover. We would encourage the authors to resequence some short fragments that cover the sites listed above.

YONG-GANG YAO,<sup>1</sup> VINCENT MACAULAY,<sup>3</sup>  
TOOMAS KIVISILD,<sup>4</sup> YA-PING ZHANG,<sup>1,2</sup>  
AND HANS-JÜRGEN BANDELT<sup>5</sup>

<sup>1</sup>*Kunming Institute of Zoology, Chinese Academy of Sciences, and* <sup>2</sup>*Laboratory for Conservation and Utilization of Bio-resource, Yunnan University, Kunming Yunnan, China;* <sup>3</sup>*Department of Statistics, University of Oxford, Oxford, United Kingdom;* <sup>4</sup>*Institute of Molecular and Cell Biology, Tartu University, Tartu, Estonia; and* <sup>5</sup>*Fachbereich Mathematik, Universität Hamburg, Hamburg*

## References

- Derbeneva OA, Sukernik RI, Volodko NV, Hosseini SH, Lott MT, Wallace DC (2002) Analysis of mitochondrial DNA diversity in the Aleuts of the Commander Islands and its implications for the genetic history of Beringia. *Am J Hum Genet* 71:415–421
- Eyre-Walker A, Smith NH, Maynard Smith J (1999) Reply to

- Macauley et al (1999): mitochondrial DNA recombination: reasons to panic. *Proc R Soc Lond B* 266:2041–2042
- Forster P (2003) To err is human. *Ann Hum Genet* 67:2–4
- Herrnstadt C, Elson JL, Fahy E, Preston G, Turnbull DM, Anderson C, Ghosh SS, Olefsky JM, Beal MF, Davis RE, Howell N (2002) Reduced-median-network analysis of complete mitochondrial DNA coding-region sequences for the major African, Asian, and European haplogroups. *Am J Hum Genet* 70:1152–1171 (erratum 71:448–449)
- Ingman M, Kaessmann H, Pääbo S, Gyllensten U (2000) Mitochondrial genome variation and the origin of modern humans. *Nature* 408:708–713
- Kivisild T, Villems R (2000) Questioning evidence for recombination in human mitochondrial DNA. *Science* 288:1931
- Maca-Meyer N, González AM, Larruga JM, Flores C, Cabrera VC (2001) Major genomic mitochondrial lineages delineate early human expansions. *BMC Genetics* 2:13
- Silva WA Jr, Bonatto SL, Holanda AJ, Ribeiro-dos-Santos AK, Paixão BM, Goldman GH, Abe-Sandes K, Rodriguez-Delfin L, Barbosa M, Paço-Larson ML, Petzl-Erler ML, Valente V, Santos SEB, Zago MA (2003) Correction: mitochondrial DNA variation in Amerindians. *Am J Hum Genet* 72:1346–1348 (in this issue)
- Yao Y-G, Kong Q-P, Bandelt H-J, Kivisild T, Zhang Y-P (2002) Phylogeographic differentiation of mitochondrial DNA in Han Chinese. *Am J Hum Genet* 70:635–651
- Yao Y-G, Macauley V, Kivisild T, Zhang Y-P, Bandelt H-J (2003) To trust or not to trust an idiosyncratic mitochondrial data set. *Am J Hum Genet* 72:1341–1346 (in this issue)

Address for correspondence and reprints: Dr. Yong-Gang Yao, Kunming Institute of Zoology, Chinese Academy of Sciences, 32 Jiaochang Donglu, Kunming, Yunnan, 650223, China. E-mail: ygyaozh@yahoo.com

© 2003 by The American Society of Human Genetics. All rights reserved. 0002-9297/2003/7205-0032\$15.00

*Am. J. Hum. Genet.* 72:1349–1352, 2003

## A Multicolor FISH Assay Does Not Detect DUP25 in Control Individuals or in Reported Positive Control Cells

To the Editor:

Gratacòs et al. (2001) reported recently that the co-occurrence of panic and phobic disorders with joint laxity was associated with an interstitial duplication of the chromosomal region 15q24–q26 (named “DUP25”). DUP25, which encompasses a region of the size of 17 Mb, was observed only as mosaicism in three different forms (designated as “direct telomeric,” “inverted telomeric,” and “centromeric”). In each reported case, cells with DUP25 represented the majority (>50%). In addition, DUP25 mosaicism was also observed in 7% of control individuals, indicating that it could represent a